

# SP260

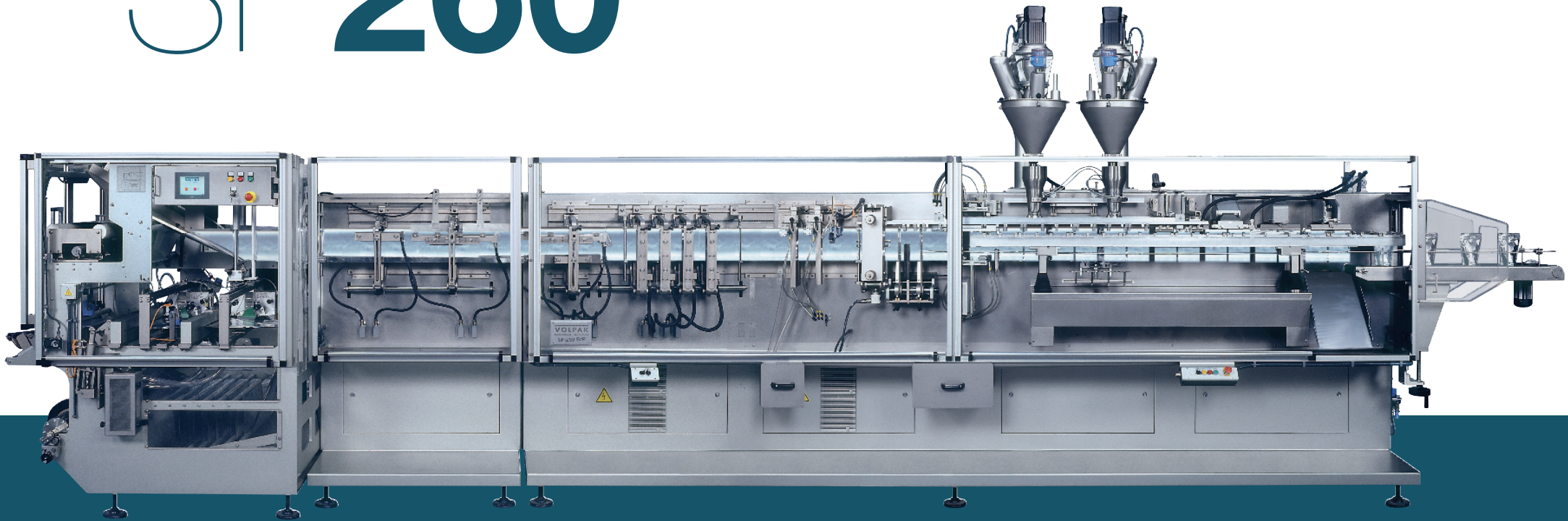

## **Características**

Su gran versatilidad permite ser la máquina ideal para una gran variedad de proyectos tanto para productos secos como líquidos. Puede incluso realizar formatos de gran tamaño lo que permite dar respuesta satisfactoriamente a la mayoría de aplicaciones del mercado. La SP 260 es la máquina de mayor aceptación para el envasado de productos alimenticios tipo quesos rallados, salsas, mayonesas, y también alimentación para mascotas, champús, suavizantes, etc.

## **Characteristics**

*Thanks to its versatility the SP-260 is the ideal machine for a wide variety of projects both for dry and liquid products. Furthermore it also can produce large formats covering a wide spectrum of the major application in the market of flexible packaging. It is mostly seen in the food industry for cheese, sauces, ready made meals, in the pet food industry and in home and health care for shampoos, softeners, dish washing liquids, etc.*

# SP260

## Datos técnicos *Technical data*

		SP260	
		SIMPLEX	DUPLEX
FORMATO SOBRE (A x H x F) / POUCH FORMAT (W x H x G)	MIN. (mm)	70 x 60 x (30)	50 x 60 x (30)
	MAX. (mm)	260 x 310 x (125)	130 x 310 x (125)
VOLUMEN (sin y con fondo) / VOLUME (without and with gusset)	MAX. (cc.)	700 / 2000	350 / 600
VELOCIDAD (sobres/min) / OUTPUT (pouches/min)	Hasta / Up to:	80	160
MATERIAL ENVASE / FILM MATERIAL		TERMOSELLABLE/HEATSEALABLE	
DIM. BOBINA / REEL DIMENSIONS (mm)	DIAM. MAX.	600	
	ANCHO MAX. WIDTH	745	
	NUCLEO / CORE DIAM.	70 / 72 - 150 / 152	
DATOS ELECTRICOS / ELECTRICAL DATA		220,380,440 V / 50,60 Hz	
NIVEL SONORO / NOISE LEVEL		Inferior a / Below 70 dB	
MEDIDAS MAQUINA / MACHINE DIMENSIONS	(mm; L x A x H)	6150 x 1650 x 1800	
PESO NETO / NET WEIGHT	Kg (aprox.)	6000	

Nos reservamos el derecho a introducir modificaciones técnicas sin previo aviso. We reserve the right to introduce technical modifications without previous notice.

1. Bobina / Reel
2. Empalme de film / Film splicing
3. Desenrollador / Unwinder
4. Perforadores / Gusset perforator
5. Alineador de banda / Band aligner
6. Triángulo formador / Forming triangle
7. Guías film / Film guides
8. Desbobinador zipper / Zipper unwinder
9. Soldador zipper / Zipper seal
10. Punteador zipper / Zipper tacking
11. Soldadura inferior / Botton seal
12. Soldadura vertical / Vertical seal
13. Muesca desgarre / Tear notch
14. Fotocélula / Photocell
15. Arrastre por rodillos servomot / Servo rollers for film transport
16. Tijera / Knife
17. Tijera corte unitario / Knife and unitary cutting
18. Apertura sobre / Pouch opening
19. Ventosas apertura fondo / Botton pouch opening
20. Etaciones de dosificado / Fillings stations
21. Estirado estático / Pouch stretching
22. Soldadura superior / Top sealing
23. Estación de rechace / Pouch reject station
24. Rampa de rechace / Reject ramp
25. Cinta de salida / Outlet belt

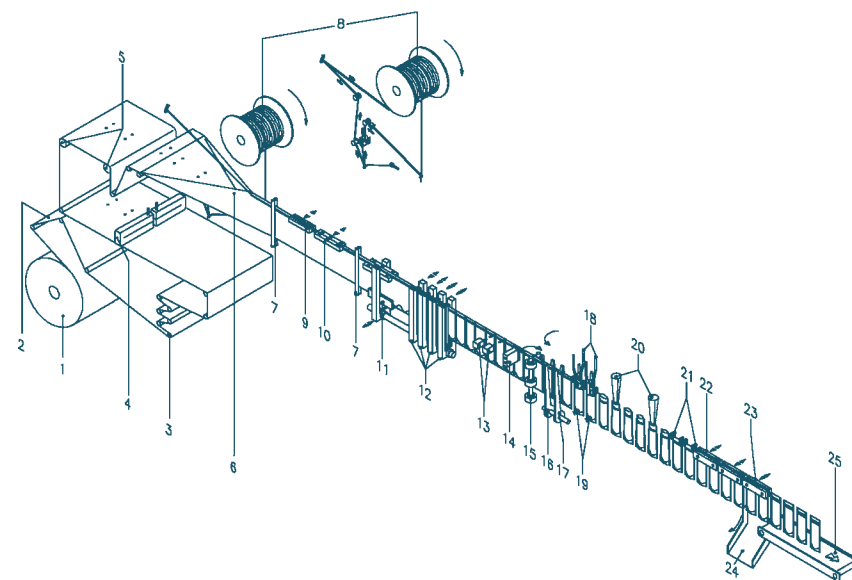

### Tipos de sobre Standard pouches

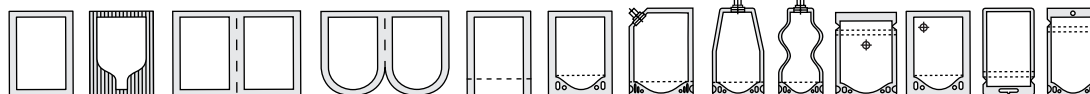

**VOLPAK**

**VOLPAK, S.A.U.**  
Pol. Ind. Can Vinyalets c/ Can Vinyalets, 4  
E-08130 Santa Perpètua (Barcelona), Spain  
Tel. +34 93 544 67 00 Fax. +34 93 574 11 36  
E-mail: main@volpak.com

**VOLPAK NORTH AMERICA**  
501 Southlake Boulevard  
Richmond, VA 23236  
Tel. 1 804 7946688  
Fax. 1 804 7946187

**VOLPAK ARGENTINA**  
Av. Juan B. Justo, 5855  
7600 Mar del Plata  
Tel. 54 223 4784476  
Fax. 54 223 4784477

**VOLPAK INDIA**  
Plot No. 49, 50, Gat No. 343,  
Next to HP Gas Warehouse,  
Chakan - Talegaon Rd, Mahalunge Ingle, Khed  
Pune - 410 501, Maharashtra State  
Tel. +912135615900 Fax. +912135615911



www.volpak.com