

Mafo Cleaning Equipment B.V.
P.O. Box 212, 7600 AE Almelo,
Wierdensestraat 226, 7604 BS Almelo,
The Netherlands

T: (+31) 546 575360
F: (+31) 546 575316
I: www.mafo.nl
E: sales@mafo.nl



Mafo 230M:

- Compact
- Modular
- Efficient
- Low priced
- Energy saving
- Water saving
- Stainless steel
- Safe
- Reliable
- Environment-friendly
- User-friendly

Mafo 230M

Mafo 230M

**Capacity*

This washing machine is designed for a nominal capacity of maximum 400 crates per hour, but the actual capacity varies with crate sizes and type or amount of soil to be removed from the crates.

**Design*

The compact modular construction of the machine combines easy operation with a high degree of efficiency. When equipped with a looping track, one person can even operate the machine. The safety of the operator has been one of the major design criteria.

**Operation*

Water is circulated in the main wash section of the **Mafo 230M** and filtered before used for washing again. The filter can be cleaned quickly and easily.

The water from the separate final rinse section is directed continuously to the main wash tank and this compensates for the loss of water that leaves the machine with the washed products and the loss due to evaporation.

The water in the main wash section is thus constantly refreshed. The result is the reduction of water and energy consumption to a minimum.

**Modular*

The **Mafo 230M**, together with the **Mafo 340M** form the basis of the **Mafo** modular system. This modular system offers many possibilities for custom-built solutions, also in combination with blow-off units.

**Conclusion*

Using stainless steel and other high quality materials results in the lowest the maintenance and service costs of the **Mafo 230M**. All this makes the **Mafo 230M** a good investment for your operations.

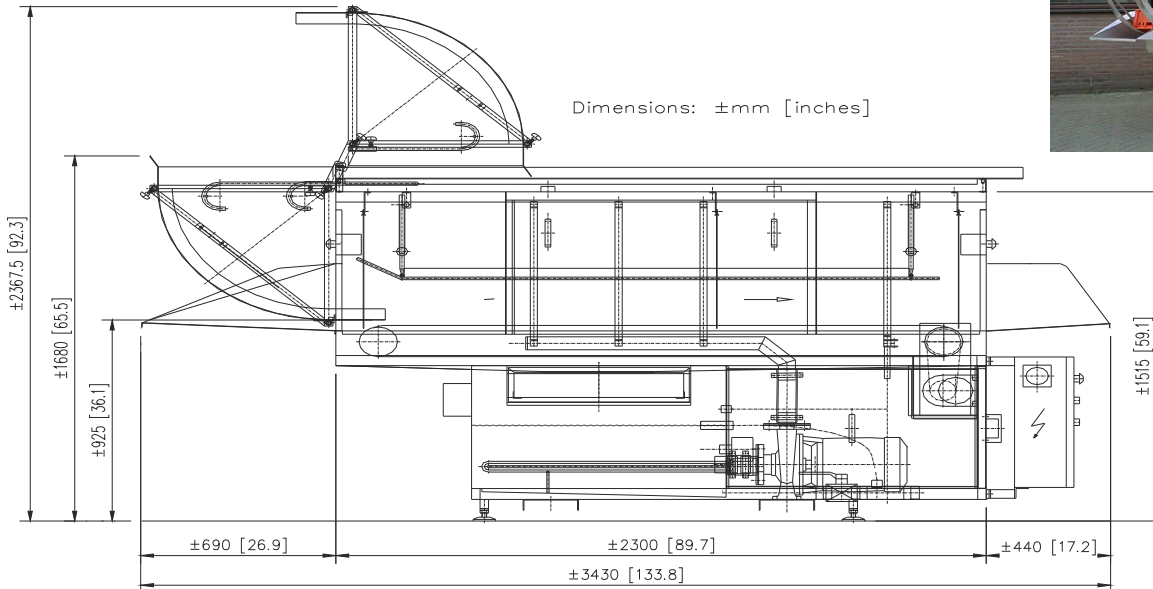

Mafo 230M

Technical data	Mafo 230M		
Capacity	150 - 400 crates/h	Supply	400V-3~, N, PE, 50 Hz
Max transit width	800 mm	Water connection	¾" BSP
Max transit height	400 mm	Drain connection	2" BSP
Infeed height	925 mm	Steam connection	1" BSP
Machine width	1050 mm	Nozzles final rinse	16 pcs, Ms
Water consumption	Product related		
Tank volume	250 l	400 l	400 l
Pump performance	5.5 kW	7.5 kW	11 kW
Pump capacity	45 000 l/h at 2.9 Bar	60 000 l/h at 2.9 Bar	72 000 l/h at 4.2 Bar
Nozzles main wash	50 pcs, Stainless steel	70 pcs, Stainless steel	65 pcs, Stainless steel
Possible configurations:			
Heating	Live steam injection, steam coil, hot water coil, electric heating	Hold-down system	Swinging hold-down, hold-down gas spring assisted
Filtration	Filter tray, belt filter, rotating drum filter	Side guides	Raster system, swinging and from outside adjustable
Motor drive conveyor	1-speed motor drive, variable speed motor drive by frequency inverter	Vapour extraction	Axial fan, centrifugal fan with piping, condensor
Conveyor	Stainless steel chain, Stainless steel mess belt, conveyor belt		
Other options:	- Tunnel- en tank insulation	- Driven tables	- Looping track
	- Product counter	- Glide tables	- Specially designed transit width
	- Dosing equipment	- Roller tracks	