

## Semiautomatic bag packer

### *olibag 210*

- » Suited for bags, blister wraps, flat or upright products, tubes or folding boxes
- » Product is supplied and sorted fully automatically
- » Modular design extendable with the *olimat* + *oli-pal* to operate as a fully automatic final packaging line
- » Processing is gentle on products offering highest process safety

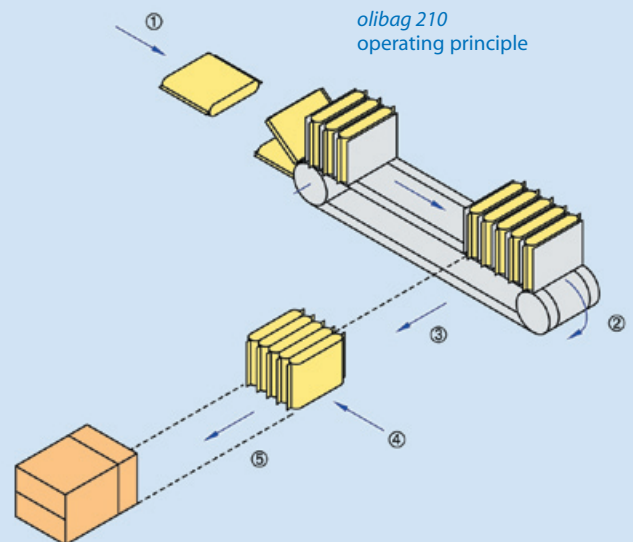



>> Bag infeed      >> Flighted indexing chain      >> Push-off by rake      >> Intermediary table      >> Pressing of the bag block      >> Insertion into the case      >> Manual removal

## Semiautomatic bag packer

### olibag 210

This standard bag packer is the semiautomatic basic module. It can be easily extended to operate as a fully automatic final packaging line with the

>> **olimat** case erector/sealer



olimat 1

and the >> **oli-pal** or the **oli-pal Duplex compact palletiser**



oli-pal A

### General information

Can be applied in all industries. Space-efficient design. Superior workmanship/material quality and refined operationability in all details:

- Completely welded frame makes it particularly stable
- High performance
- Extremely smooth running
- Operator panel with multi-lingual text display or touchscreen panel
- Extensive format range, format is changed quickly
- Servo motors drive all relevant motion
- Practically maintenance free

### Technical information

Output: up to 200 indexing cycles/min (with double flighted indexing chain)

Format range:

max. feed width (mm): 200/300/400, depending on model

Operating voltage/required power: 3 x 230/400 V/N/PE, 50/60 Hz, 1 kVA

Air pressure: approx. 3 - 6 bar

Floor layouts: Left or right-hand variants to customer preference

Change over time: approx. 5 - 15 min

Note:

oli packaging machinery is customized in terms of output, colour, installed load, etc., to suit the specific customer application. All machinery can be designed inversely for every format.

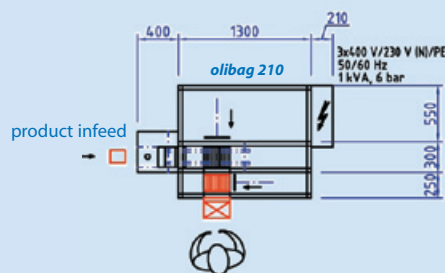
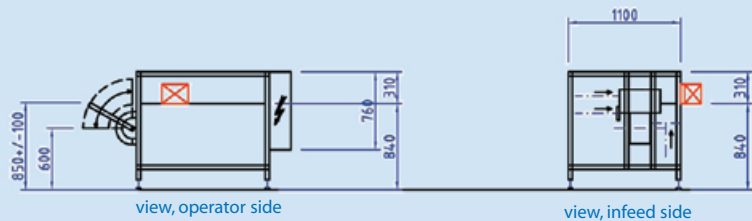

Layout (scale: 1:75)



pack'solutions  
customized

O. Lingenfelder  
**oli-Spezialanlagen GmbH**  
Blumenstrasse 17-21  
82538 Geretsried  
GERMANY  
Phone +49 8171 96 73-0  
Fax +49 8171 96 73-10  
E-mail buero@oli-gmbh.de  
[www.oli-gmbh.de](http://www.oli-gmbh.de)

oli agency